

MY-TE Winch and Hoist
OPERATION and MAINTENANCE
Guide

Cat. No. AIR1000
1250 Lb. Single Line Pull

READ THIS BEFORE OPERATING UNIT

INSTALLATION:

Mount on clean, flat surface. Use 1/2" mounting bolts with lock washers – Grade 5 or better. For ease of service, we do not recommend welding frame to surface. The AIR1000 may be upright mounted, bulkhead mounted or upside down mounted. The mounting location should be selected so the operator has a direct line of sight with the winch and the load at all times. The mounting location should also be selected so the winch is accessible for service. For proper cable spooling, allow at least 12' between the winch and the nearest guide sheave or roller. Provide clean, dry, lubricated air. The AIR1000 requires 100 P.S.I. @ 65 CFM. Install an emergency shut off valve on the air supply adjacent to the winch.

WIRE ROPE SELECTION, INSTALLATION AND SAFETY:

My-te Products, Inc. provides 7x19 Galvanized Aircraft Cable. Other wire rope construction and material is available on request. If wire rope is not purchased from My-te, select a wire rope suitable for multiple layer winching and hoisting applications. Consult your wire rope supplier for more information. Use wire rope of proper length and diameter for the application. The 1/4" diameter 7 x19 galvanized aircraft cable provided by My-te has a safe working load of 1400 Lb. on a single part line and is suitable for most AIR1000 applications. Wire rope can be damaged by installing more rope on the drum than the application calls for. In addition, the pulling capacity of the winch is reduced with every layer of rope on the drum. See product specifications for more information on pulling capacities. Wire rope failure can cause property damage, serious injury, or death. The AIR1000 is provided with a cable tensioner bar that maintains constant pressure on the rope against the drum. It is designed to prevent the wire rope from fouling or riding over the drum flanges. Prior to installing the cable, operate the winch so the cable clamp rotates to the 12:00 position. Shut off the air supply to the winch while securing the rope to the drum. To install the cable, loosen and/or remove the cable clamp screws. Pass 2" of rope through the hole in the drum flange. Replace the cable clamp and tighten the screws securely. Verify that the cable clamp screws do not extend through the drum flange to the point of interference with the rope or tensioner bar. Operate the winch to install the cable. For best results and cable life, the rope should be spooled onto the drum evenly and under tension. Loose or poorly spooled rope on lower layers may be damaged by outer layers of rope under load. Loose rope on lower layers may also affect the pulling power of the winch. Maintain at least 4 wraps of rope on the drum at the maximum reach. The drum cable clamp is not designed to hold the load. Inspect wire rope, hooks, fittings, sheaves and hoisting blocks periodically. Inspection of wire rope and fittings should be performed by trained, competent personnel. Multiple layer winches subject wire rope to crushing and abrasion that require frequent inspection and wire rope replacement.

OPERATION:

Material handling applications require specific skills, knowledge and experience. My-te winches should only be operated by competent, trained personnel. Perform a test lift or pull prior to operation each day to verify the condition of the winch, wire rope and rigging. During operation of the winch, the operator must constantly monitor the winch, rope, load and areas under or adjacent to the load path. The AIR1000 is designed for intermittent duty operation. My-te recommends a 50% duty cycle (30minutes/Hr.). To prevent shock loading, slowly remove slack from cable before full load is moved. Remote control pendant switch provides forward and reverse control through pilot air which controls the main air valve. Pulling Power is the same in either direction. Do not allow personnel to stand under or adjacent to the load path of a moving load at any time. Always maintain at least 4 wraps of cable on the drum. Do not allow the load to be lifted or pulled or lowered into any obstructions in the load path. Do not allow the load to be lifted or pulled into the winch or the winch mount.

MY-TE WINCH-HOISTS ARE DESIGNED FOR MATERIAL HANDLING USAGE ONLY.

Catalog No. AIR1000

MAINTENANCE:

Check all sheaves, rollers and areas of friction. Be sure they rotate freely. Misalignment of cable, dragging sheaves, or rollers will consume a great amount of power.

If the unit is installed outside, be sure to provide a cover to protect motor and controls from the weather. When the unit is in operation be sure cover is completely removed.

Periodic inspection of pendant, hose and supply air connections should be made to detect any damage, leaks or cuts that which would require replacement or maintenance.

Periodically inspect the drive chain. Lubricate and tighten the chain as needed using the chain tension nut located below the chain guard.

Periodically clean main air valve exhaust mufflers.

The gearbox contains 90 weight worm gear oil. See attached 'Lubrication Guide' for more information.

TROUBLE SHOOTING AND REMEDIES:

CAUTION: BEFORE SERVICING OR INSPECTING UNIT FOR PROBLEMS BE SURE TO SHUT OFF OR DISCONNECT SUPPLY AIR.

If the unit does not run:

Check supply air. Be sure compressed air flows freely to the main air control valve.

Check pendant hoses for any obstructions which would prevent pilot air from reaching and exhausting through the push buttons.

Check push buttons for obstructions that would prevent exhausting.

If the unit runs but does not operate to capacity:

Check the main air valve exhaust mufflers for any foreign substance that would prevent exhausting.

Verify that the supply air is of the proper pressure and capacity (100 psi @ 65 cfm).

Check to be sure there is no interference in the chain, sprockets, or cable drum that would cause friction and rob power from the winch.

If the procedures above do not fix the problem, remove the winch from service for repair by the factory or a qualified repair facility.

WARRANTY:

All My-te winch-hoists are designed for material handling use only. My-te Products, Inc. warrants each My-te winch-hoist to be free of defects in material and workmanship for a period of one year. This warranty does not cover abuse, neglect or use above or beyond rated capacity and duty cycle. Warranty coverage includes shipping charges, one way, by standard ground service. Warranty does not cover cost of installation or removal of winch-hoist from service or loss due to downtime or time out of service. My-te will not reimburse unauthorized warranty expense. The final responsibility for fit of winch-hoist with application rests with end user. The warranty is void if the winch-hoist is altered or parts substituted. This warranty is limited to repair or replacement at manufacturer's factory or a point designated by the manufacturer. Inspection by the manufacturer will determine manufacturer's liability.

My-te Products, Inc.

9880 East 30th St., Indianapolis, IN 46229

317-897-9880 (ph)

317-897-9811 (fax)

www.myte.com

sales@myte.com (E-mail)

MY-TE WINCH-HOISTS ARE DESIGNED FOR MATERIAL HANDLING USAGE ONLY.

AIR1000 Parts List

COMMON FASTENERS AND OTHER ITEMS NOT SHOWN HERE ARE AVAILABLE THROUGH MY-TE PARTS DEPT OR YOUR MY-TE DEALER.

| ITEM | QTY | PART No. | DESCRIPTION |
|------|-----|----------|--|
| 1 | 1 | 052531 | Main Shaft, Long w/o Clutch |
| 2 | 1 | 058051 | Worm Shaft Assy |
| 3 | 1 | 068140 | Drum Assy, Long Cast |
| 4 | 1 | 081511 | Cap, Worm Gear Hsg |
| 5 | 1 | 081530 | Cap,Worm Gear Hsg for Seal |
| 6 | 1 | 082011 | Cover, WGH Closed |
| 7 | 1 | 088110 | Housing, Worm Gear w/Studs |
| 8 | 1 | 113010 | Worm |
| 9 | 1 | 113030 | Worm Gear,Bronze-No Clutch |
| 10 | 1 | 142230 | Upright Assy,Motor Mtg - Air |
| 11 | 1 | 143760 | Block, Chain Tensioner |
| 12 | 1 | 148360 | Tensioner Bar Assy / Hdw 100A |
| 13 | 1 | 148470 | Flame Assy, Air Winch Hoist |
| 14 | 1 | 171280 | Spacer, Thick Main Shaft |
| 15 | 1 | 171310 | Spacer, Thin Main Shaft |
| 16 | 2 | 211010 | Bearing, Main Shaft |
| 17 | 2 | 211020 | Stamping, Flangette Bearing |
| 18 | 1 | 211030 | Bearing, Flangette & Collar |
| 19 | 2 | 211040 | Bearing, Worm Shaft- Cone |
| 20 | 2 | 211050 | Bearing, Worm Shaft - Cup |
| 21 | 1 | 211560 | Bushing, $\frac{1}{2}$ x $\frac{3}{8}$ -Black Pipe |
| 22 | 1 | 241010 | Oil Seal, Main Shaft - Standard - 1 x 2 |

| ITEM | QTY | PART No. | DESCRIPTION |
|------|-----|----------|--|
| 23 | 1 | 241040 | Oil Seal, Hand Crank - .75 x 1.25 |
| 24 | 1 | 241510 | Gasket,Worm Gear Hsg |
| 25 | 2 | 241530 | Gasket,Worm Hsg Cap 1/32 |
| 26 | 2 | 241540 | Gasket,Worm Hsg Cap .010 |
| 27 | 3 | 282770 | Set Screw, Cable Drum $\frac{1}{16}$ -18 x 1/2 SSS Knurl Point |
| 28 | 2 | 283020 | Screw, 5/16-18 x 1 SHCS |
| 29 | 4 | 283060 | Screw, Bracket Mounting #8-32 x 2 SHCS |
| 30 | 3 | 286250 | Oil Plug, 1/8 NPT |
| 31 | 1 | 286610 | Nut, Hex Jam $\frac{3}{8}$ -24 Zinc Nylon Insert |
| 32 | 4 | 287140 | Lockwasher, Split #10 Zinc |
| 33 | 1 | 288020 | Chain Tensioner, Screw Assy - Air |
| 34 | 1 | 321530 | Snap Ring, Worm Gear Housing -2" |
| 35 | 1 | 341150 | Sprocket, $\frac{3}{4}$ Bore, #40, 24 Tooth |
| 36 | 1 | 341160 | Sprocket, $\frac{5}{8}$ Bore, #40, 11 Tooth |
| 37 | 18 | 342010 | Roller Chain, #40 |
| 38 | 1 | 342520 | Chain, Connecting Link, #40 |
| 39 | 2 | 351020 | Woodruff Key, Worm Shaft #607 - $\frac{3}{8}$ x 7/8 |

| ITEM | QTY | PART No. | DESCRIPTION |
|------|-----------|----------|---|
| 40 | 3 | 351030 | Woodruff Key, Main Shaft #1008 - $\frac{5}{16}$ x 1 |
| 41 | 1 | 471010 | Air Motor, Gast AM-NRV-7A |
| 42 | 1 | 472020 | Valve, Air, Dir Control Pressure - Piloted |
| 43 | 1 | 473030 | Hose Assy, Motor Control - $\frac{1}{2}$ x 8 $\frac{3}{4}$ / Fittings |
| 44 | 1 | 473040 | Hose Assy, Motor Control - $\frac{1}{2}$ x 8 $\frac{1}{4}$ / Fittings |
| 45 | 1 | 474035 | Tee, Street $\frac{1}{2}$ - Black Pipe |
| 46 | 3 | 474040 | Elbow, Street - 90°, $\frac{1}{2}$ NPT Brass |
| 47 | 2 | 474050 | Elbow, Male - 90°, $\frac{1}{2}$ NPT Brass |
| 48 | 3 | 474080 | Elbow, Street - 90°, $\frac{1}{8}$ NPT Brass |
| 49 | 2 | 474250 | Muffler, Valve $\frac{1}{2}$ NPT |
| 50 | 1 | 475010 | Bracket, Valve Mounting - Air |
| 51 | 1 | 478011 | Switch Assy, Complete / Hose, Fittings - Air |
| | .125 Gal. | 641510 | Worm Gear Oil |

| ITEM | QTY | PART No. | DESCRIPTION |
|------|-----|----------|-----------------------------|
| | 1 | 621020 | Decal-Oil Level |
| | 1 | 621250 | Decal-Drum Warning |
| | 1 | 621260 | Decal-Safety/ 3 x 3 |
| | 1 | 621270 | Decal-Capacity & SN |
| | 1 | 621290 | Decal-Made In America |
| | | 248022 | Seal & Gasket Kit-New Cover |

AIR1000 Parts Drawing

P/N 746010

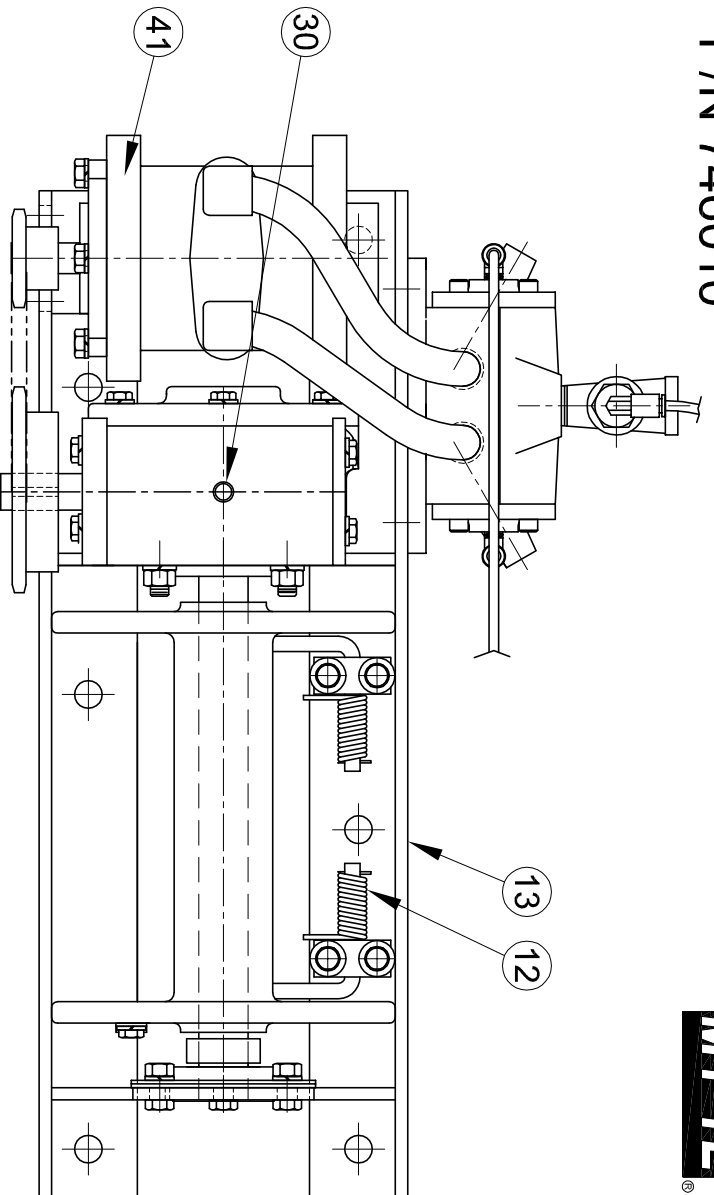

TOP VIEW

SHOWN WITH MOTOR
& MTG PARTS REMOVED

END VIEW

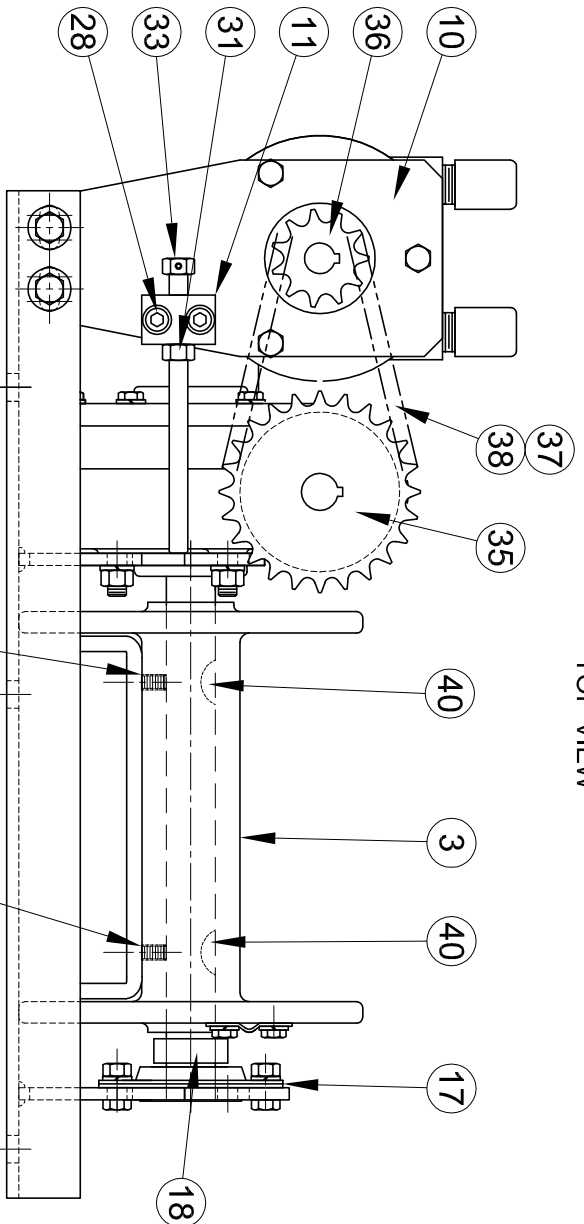
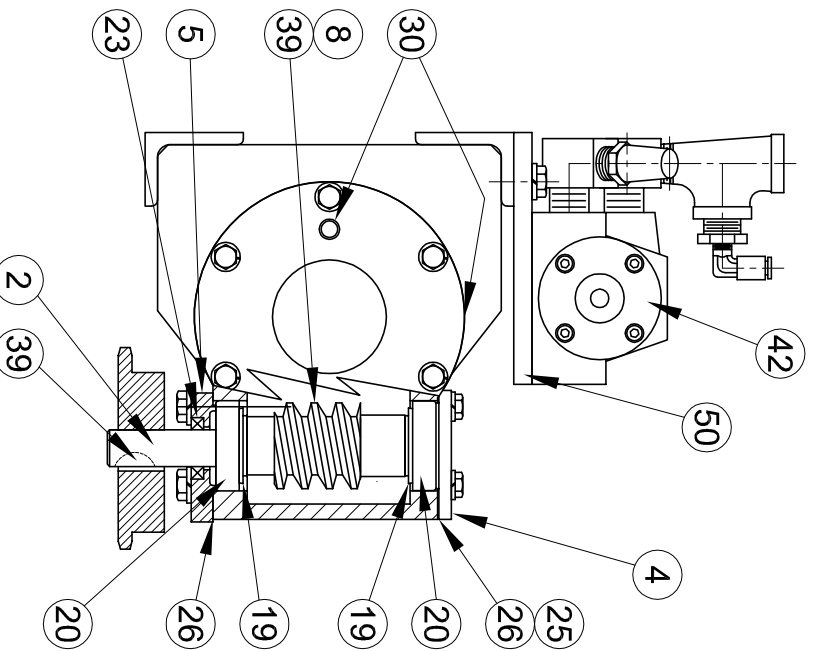

FRONT VIEW

