

I-Beam Electric Winch-Hoist 800AB

I-BEAM SERIES



Features

- 1,000-lb single-line or 2,000-lb double-line lift
- Trifecta system 115 Volt brake motor with triple brake system for instant stopping
- Worm gear reduction for positive load holding
- Low headroom—
15" single line, 19" double line
- Trolley built to beam size
- Hoist complete with cable hook and block for 20' lift
- Upper/lower adjustable limit switch
- 10' pendant control

Applications

All My-te winches and hoists are designed for material handling usage only.

All-purpose lifting

Long-lift applications where chain hoist will not reach

In-plant operation where a hoist hanging from I-beam supports the load

I-Beam Electric Winch-Hoist 800AB

I-BEAM-SERIES

Construction Features:

- Hoist mounted to 3/8" steel trolley with 4" I-beam wheels
- Fully sealed aluminum housings, with precision-cut gears, run in an oil bath
- Hardened steel worm and forged bronze worm gear holds load in position when stopped
- Stress-proof drum shaft
- Frictionless bearings
- 286:1

Trolley Size:

Trolley is built to fit the size of beam specified, from 4" to 15" structural I-beams.

We must have your I-beam size. Example: 8" high x 4" wide

Power:

- Universal 18,500 RPM reversible 1.25 HP brake motor (no-load speed)
- 15' power cord plugs into any 115 Volt AC grounded outlet
- 6 amp – No load
- 14 amp – Full load

Lifting Capacity:

- 1,000 lbs – 1-2 layers of cable (39' of 1/4" cable)
- 850 lbs – 3 layers of cable (65' of 1/4" cable)
- 600 lbs – full drum of cable (250' of 1/4" cable)

Speeds:

- 59 RPM: No-load drum speed
- 30 FPM: No-load drum speed
- 25 FPM: 500 lbs – single-line lift
- 20 FPM: 1,000 lbs – single-line lift
- 10 FPM: 2,000 lbs – double-line lift

Note: All speeds are based on one layer of cable on drum.

Drum Storage:

Unit has adjustable upper and lower limit switch. Hoist is provided with 42' of 1/4" cable for 40' lift, single line, and 20' lift, double line. Sheave block and safety hook are included. Applications needing longer than 100' cable lengths require hoist without limit switch or with upper limit switch control only.

- 1/8" – 1,000' • 1/4" – 250'
- 3/16" – 450' • 5/16" – 150'

For best results, use the minimum amount of cable required for application. Maintain four wraps of cable on the drum at all times. Cable sold separately. Length and size must be specified at time of order.

Cable Strength:

- Safe working load is 20% of breaking strength
- Top-quality galvanized cable available in the following breaking strengths:

1/8" – 2,000 lbs	1/4" – 7,000 lbs
3/16" – 4,200 lbs	5/16" – 9,800 lbs

Duty Cycle:

- 25% – 15 min/hr when operating at full load

Shipping Weight: 133 lbs

Factory-Installed Options:

- 230 Volt
- 12 Volt DC – Model 80-12
- 3-ton hoist – Model HAC 36B
- Lug mount trolley
- Motorized trolley hoist
- Upper limit switch only

For custom design and application assistance of a My-te winch-hoist, see your My-te distributor or call My-te Products, Inc. (800) 840-9880. Visit us at www.myte.com

FRONT VIEW

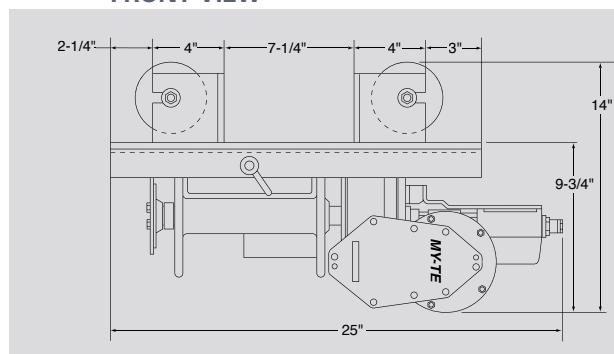

TOP VIEW

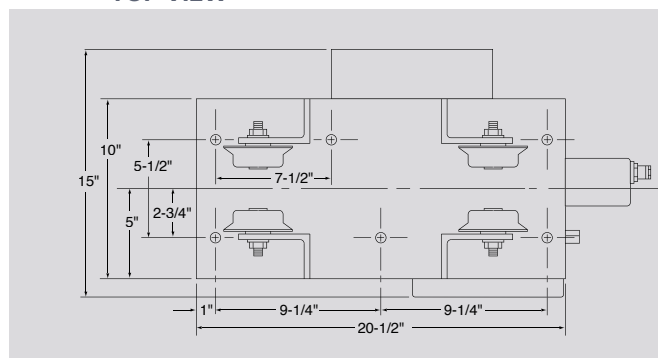

SIDE VIEW

